



## WVK2 Volume Flow Rate Controllers Technical Data for Actuators - Installation Instructions

### Technical data for actuators

	M1	M2	M3
Connection voltage	230 V~	24 V≅	24 V≅
Operating range	85 to 265 V	19.2 to 28.8 V	19.2 to 28.8 V
Run time for 90°	150 s	150 s	150 s
Input power supply	≤6 VA	≤4 VA	≤4 VA
Energy consumption	≤2.5 W	≤2 W	≤2 W
Degree of protection	IP 54	IP 54	IP 54
Connecting cable 0.75 mm <sup>2</sup>	approx. 1 m 3 core	approx. 1 m 3 core	approx. 1 m 4 core
Ambient temperature	-30 to +50°C	-30 to +50°C	-30 to +50°C

### Actuator M1

1 wire control

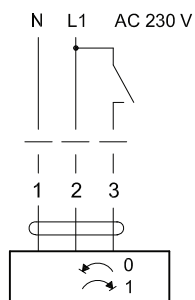

2 wire control

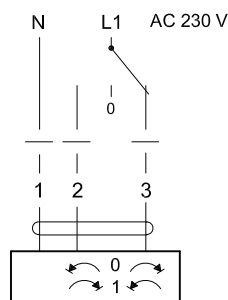

### Actuator M2

1 wire control

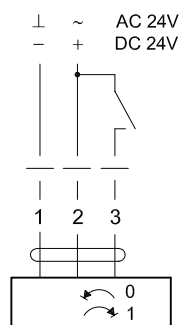

2 wire control

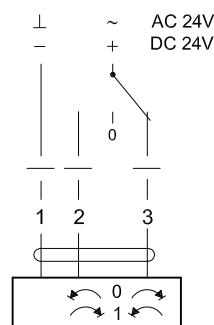

### Actuator M3

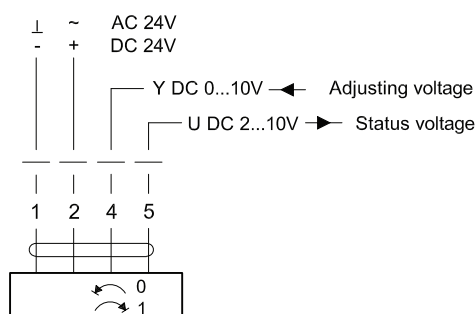

### Installation instructions

- WVK2 volume flow rate controllers are calibrated over the entire range of application of the product.
- The installation of the controller requires a straight inlet path with a minimum length of 3 times nominal width *W* and a straight outlet path of at least 1.5 times nominal width *W*. Installation directly before or after points that cause turbulence (bends, junctions etc.) reduces the control accuracy.
- The volume flow rate set point is adjusted on installation. This adjustment does not affect the control accuracy.
- The base model is adjusted manually by moving the pointer to the required set point on the scale and fixing this setting.
- Volume flow controllers with actuator-driven setting with the M1 (230V~) and M2 (24V≅) actuators allow a two-step operation. The associated actuator limit stoppers are positioned to set the two volume flow rates.

The two limit stoppers of the actuators with 0-running direction are factory-set to the largest possible angle of rotation. The maximum angle of rotation corresponds to the largest possible volume flow rate set point. The minimum angle of rotation is the equivalent to a "shut-off" at a residual leakage rate well below the minimum volume flow rate specified in the catalogue.

M1 actuator and M2 actuator can be connected to a single wire controller or 2 wire controller.

- Volume flow rate controllers driven by the M3 (24V≅) actuator allow continuous set point adjustment. The actuator is controlled with an adjusting voltage *Y* DC = 0...10V and moves into the position specified by the control signal. The operating range starts at 2V. The volume flow rate set point change is nearly linear to the adjustment voltage.

The 0-running direction of the actuator is set in the factory, and the limit stoppers are set to give the largest possible angle of rotation, so that *Y* = 10V corresponds to the maximum angle of rotation and therefore the maximum volume flow rate set point, and 0...2V corresponds to the minimum angle of rotation, which equates to a "shut-off" at a residual leakage rate well below the minimum volume flow rate specified in the catalogue.

The status voltage *U* DC 2...10V serves to display the volume flow rate set point electrically and as a sequence control signal for additional actuators.

- All actuators are protected against overload, do not require a limit switch and stop automatically at the limit stopper.
- For manual operation, all actuators can be locked out by a self-resetting push button.
- The running direction of all actuators can be reversed with a change over switch on the actuator.
- If there is a power failure the actuator stays in its current setting and the controller continues to control at the corresponding set point.
- Installation instructions are included with the volume flow rate controllers and have to be followed.