

Author:	Tony Pepper	Creation Date:	20.11.09
Checked:		Revision:	A

Tools required:

- 1 x Large Cross Head Screwdriver
- 1 x Pop Riveter
- 1 x Ø3.5mm Drill Bit
- 1 x Battery Operated Drill

Plenum Installation

1. Install the Plenum Box prior to fitting the ceiling grid by suspending it from its mounting holes with Drop Rods (supplied by others). When the grid has been fitted, centralise the Plenum in both directions within the opening where the Diffuser is to be fitted (see fig 1).

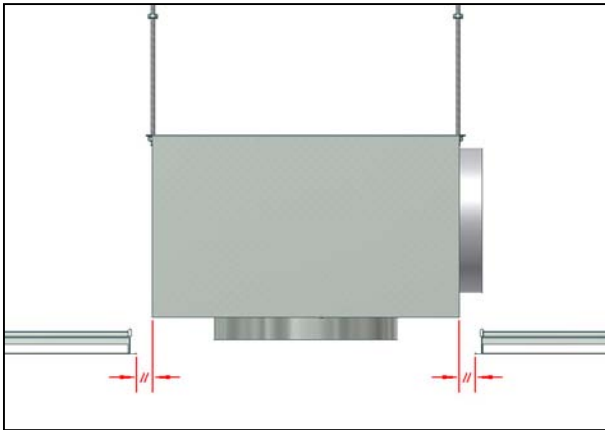


Figure 1: Centralise Plenum

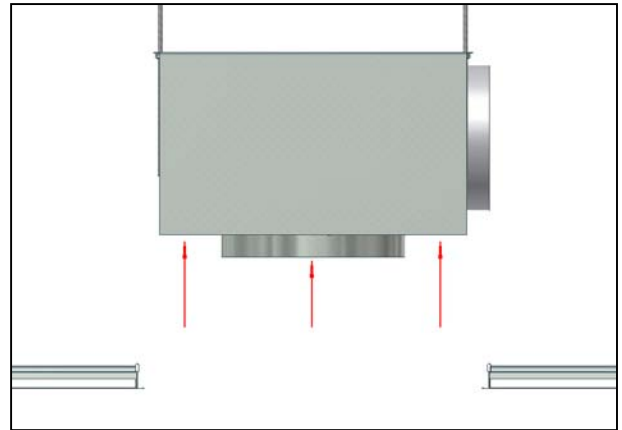


Figure 2: Raise Plenum Box

2. Once you are satisfied with its alignment within the ceiling grid, raise the Plenum Box above the grid to allow sufficient space to install the Tile (see figure 2).
3. Take a Ceiling Tile, mark out the required Diffuser position then cut out the appropriate clearance hole size. The recommended hole sizes are as follows:

Model	Cutout Size
SDFC-125	160
SDFC-160	200

Model	Cutout Size
SDFC-200	250
SDFC-250	300

Model	Cutout Size
SDFC-315	370
SDFC-400	460

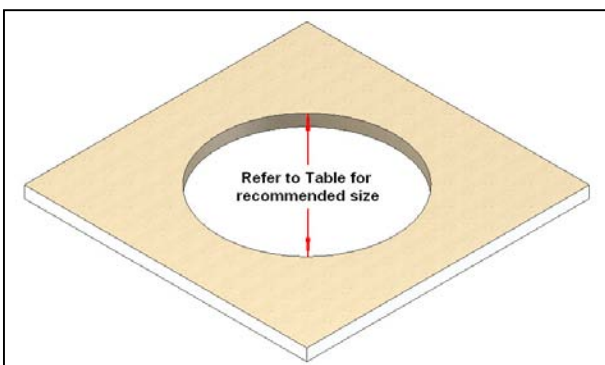


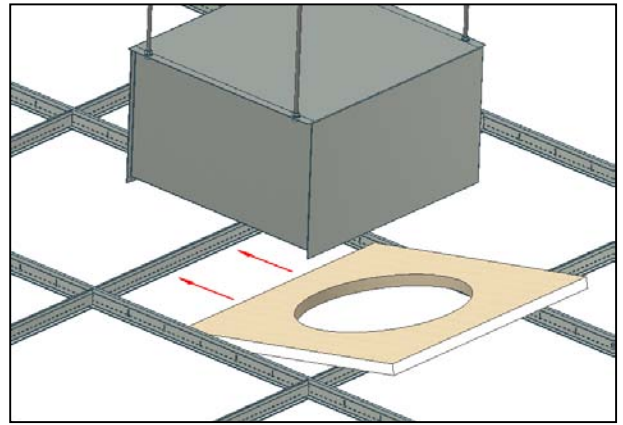
Figure 3: Cut clearance hole in Tile

**Waterloo Air Products plc**  
 Mills Road, Aylesford, Kent  
 ME20 7NB

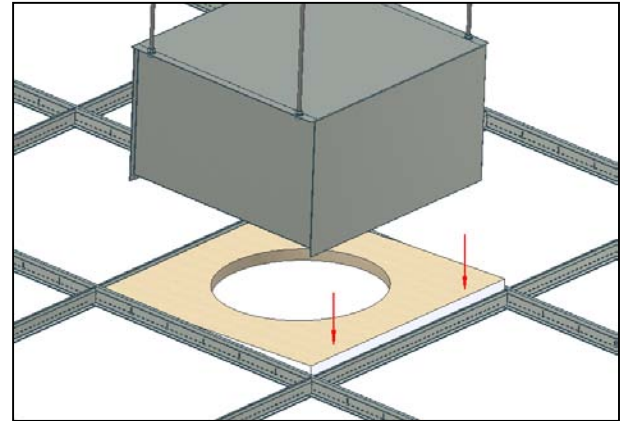
T: +44 (0) 1622 717861  
 F: +44 (0) 1622 710648  
 E: [mail@waterloo.co.uk](mailto:mail@waterloo.co.uk)  
 W: [www.waterloo.co.uk](http://www.waterloo.co.uk)

Registration No 4911865

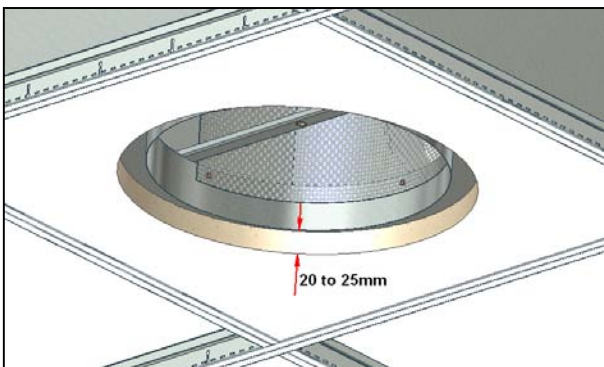
4. Locate one end of the Tile into the ceiling opening, and in a sliding motion move it to the far end of the opening (figure 4).
5. Once the Tile is positioned, lower it into the opening, ensuring that it is firmly seated against the tee bars of the ceiling grid. (See figure 5).
6. Lower the Plenum Box into the opening in the Tile, ensuring that the bottom of the Plenum Collar is between 20 and 25mm from the Tile face (figure 6). Do not tighten the Drop Rod lock nuts at this time, as some adjustment may be required.
7. Once the Plenum is positioned, offer up the Diffuser into the Tile opening making sure that the stack on the rear of the Diffuser is



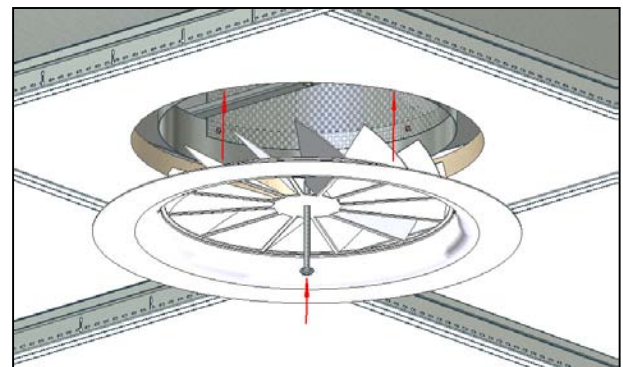
*Figure 4: Slide Diffuser into opening*



*Figure 5: Lower Diffuser into position*

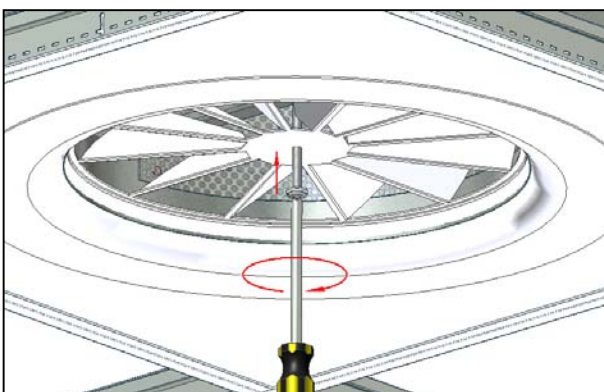


*Figure 6: Lower Plenum into opening*



*Figure 7: Offer Diffuser up into opening*

correctly located in the Plenum Mounting Collar (figure 7). Take the fixing screw from the fitting kit supplied, remove its plastic cap and secure the Diffuser to the Plenum Mounting Bar as shown in figure 7a. Take care not to over tighten the screw as this could distort to the Diffuser face.

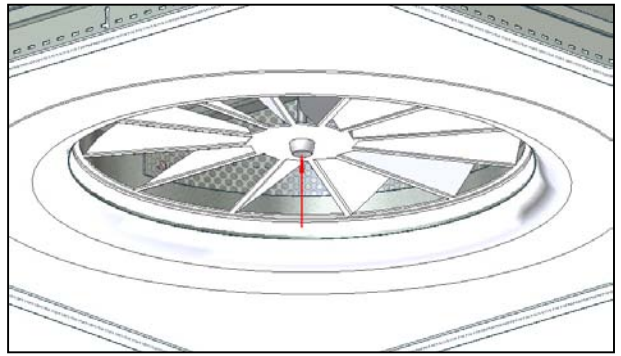


*Figure 7a: Screw Diffuser to Plenum*

**Waterloo Air Products plc**  
 Mills Road, Aylesford, Kent  
 ME20 7NB

T: +44 (0) 1622 717861  
 F: +44 (0) 1622 710648  
 E: [mail@waterloo.co.uk](mailto:mail@waterloo.co.uk)  
 W: [www.waterloo.co.uk](http://www.waterloo.co.uk)

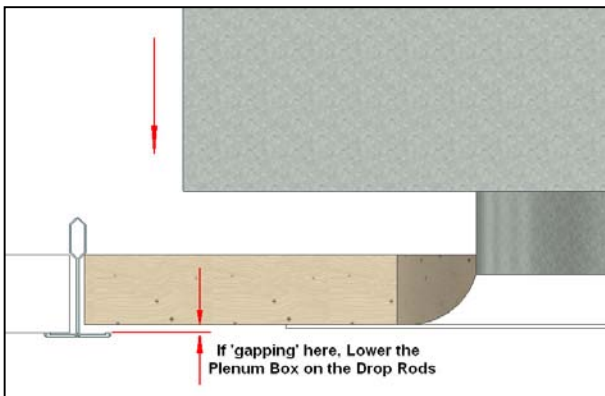
Registration No 4911865



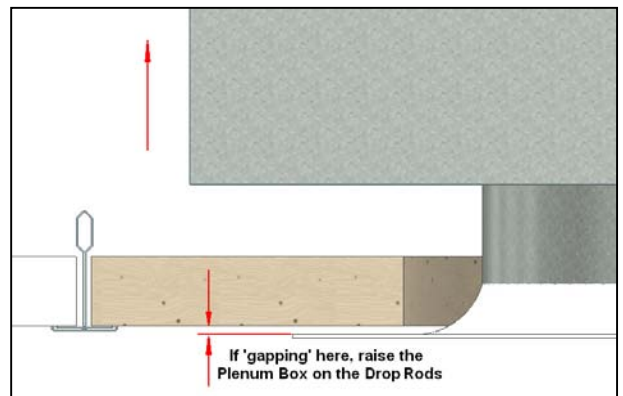
*Figure 8: Refit cap on fixing screw*

8. Clip the plastic cap back onto the head of the fixing screw (figure 8).

9. This operation may cause the Tile to be lifted off the ceiling grid creating a gapping effect, or alternatively, the Diffuser may not pull all the way up to the Tile face. If this occurs, adjust the height of the Plenum by raising or lowering the assembly using the lock nuts on the Plenum Drop Rods until the desired effect is acquired.



*Figure 9: Lower Plenum to close gap*

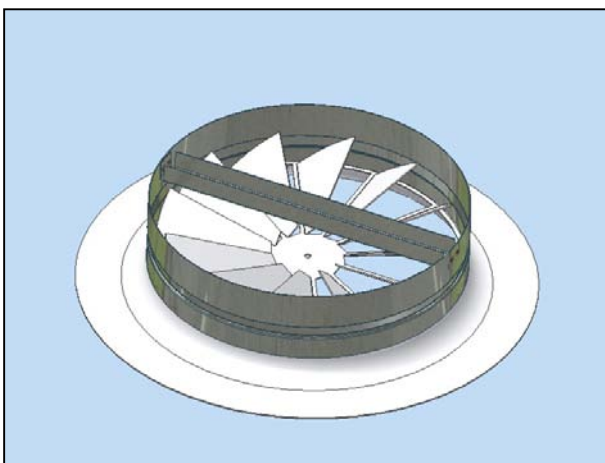


*Figure 9a: Raise Plenum to close gap*

### Duct Mount Installation

An alternative method of installing this range of Diffusers is the use of a steel Duct Mount Collar. This allows both rigid and flexible ductwork to be connected directly to the rear of the Diffuser. These Duct Mounts are supplied to order, and the installation instructions are as follows:

1. Take the Diffuser and place it face down on the table, taking care to lay it on something to protect the paint finish.
2. Orientate the Duct Collar so that its mounting bar 'U' channel is open to the top, then place the Collar over the rear stack of the Diffuser. Take care to ensure that the stack is positively located within the Collar (figure 10).



*Figure 10: Position Duct Collar on Stack*

**Waterloo Air Products plc**  
Mills Road, Aylesford, Kent  
ME20 7NB

T: +44 (0) 1622 717861  
F: +44 (0) 1622 710648  
E: [mail@waterloo.co.uk](mailto:mail@waterloo.co.uk)  
W: [www.waterloo.co.uk](http://www.waterloo.co.uk)

Registration No 4911865

- Remove the plastic cap from the fixing screw supplied. Stand the Diffuser on edge whilst still holding the Duct Collar in place, then insert the fixing screw and secure the Diffuser to the Duct Collar (figure 11). Take care not to over tighten the screw as this could distort to the Diffuser face.
- Refit the plastic cap onto the head of the fixing screw.



Figure 12: Ceiling Mounting Bracket

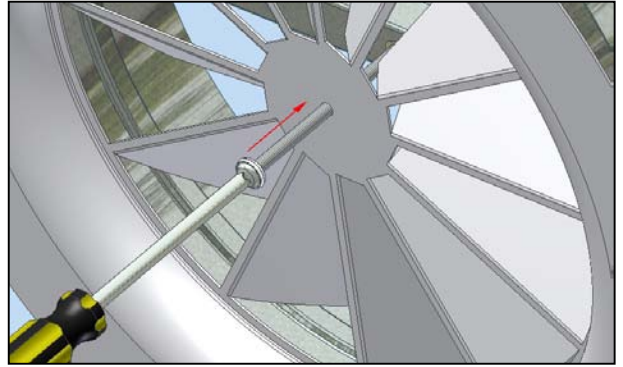


Figure 11: Screw Diffuser to Duct Collar

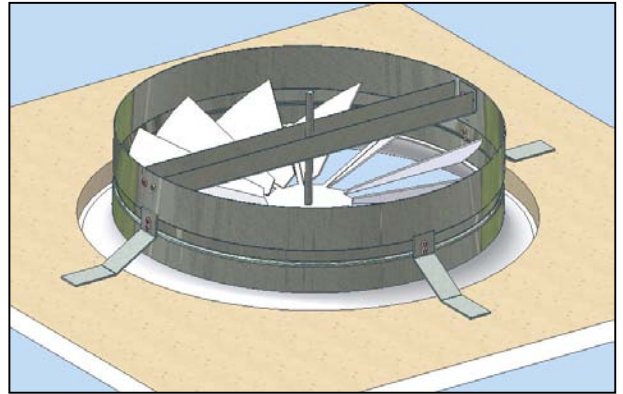


Figure 12a: Fit Mounting Brackets

- Lay the cut tile over the stack of the Diffuser and centralise its position. Take the Ceiling Mounting Brackets (figure 12) and fix them around the outside of the Duct Collar at 90° intervals (or as required) using Pop Rivets or Self Tapping Screws as shown in figure 12a. When positioning these brackets, ensure that there is sufficient tension on them to pinch the Tile and prevent any movement of the Diffuser. Please note that these brackets are supplied upon request.
- Locate one end of the Tile and Diffuser into the ceiling opening, and in a sliding motion move it to the far end of the opening (figure 13).
- Once the Diffuser is positioned, lower it into the opening, ensuring that it is firmly seated against the tee bars of the ceiling grid. (See figure 13a below).

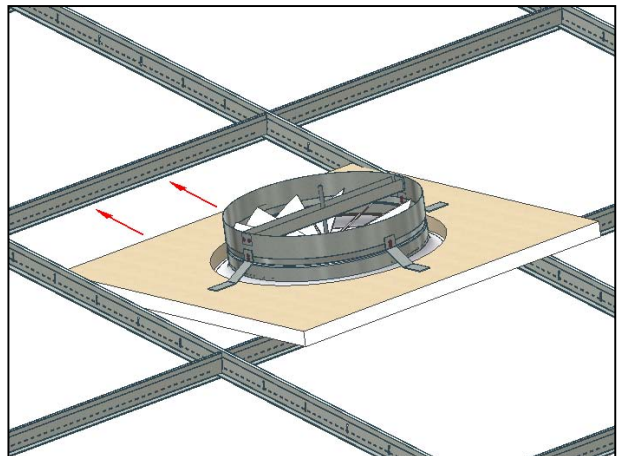


Figure 13: Slide into Ceiling Grid

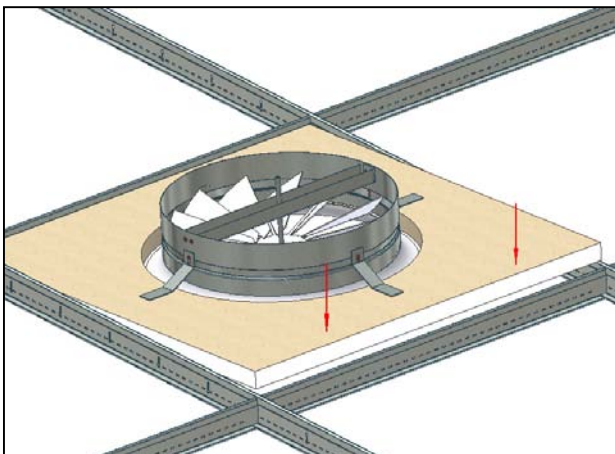


Figure 13a: Lower Diffuser into place

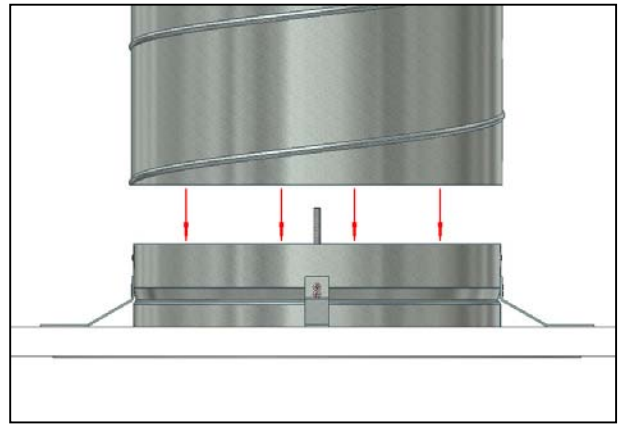
**Waterloo Air Products plc**  
Mills Road, Aylesford, Kent  
ME20 7NB

T: +44 (0) 1622 717861  
F: +44 (0) 1622 710648  
E: [mail@waterloo.co.uk](mailto:mail@waterloo.co.uk)  
W: [www.waterloo.co.uk](http://www.waterloo.co.uk)

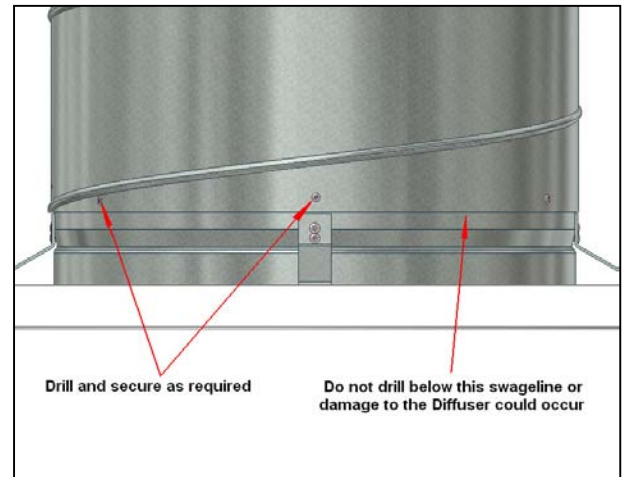
Registration No 4911865

### 8. Rigid Ductwork

- a. Lower the Ductwork on the Drop Rods to allow it to slide over the exterior of the Duct Collar (figure 14). Anchor it in position using the lock nuts on the supporting Drop Rods.
  
- b. Secure the Ductwork by drilling through it and the Duct Collar above the swage line, then riveting or screwing them in place (figure 14). Do not under any circumstances fix the ductwork below the swage line as damage to the Diffuser may occur.



**Figure 14: Lower the Ductwork**



**Figure 14: Secure Ductwork in place**

### 9. Flexible Ductwork

Place the open end of the flexible ductwork over the outside of the Duct Collar and secure in place using a worm drive hose clip.

### Cleaning and Maintenance

To clean, use warm soapy water and a damp cloth. Wipe down the Blades and Face of the Diffuser and leave to dry.