

# Light Duty Floor Grilles

## AFG



### Introduction

The Waterloo light duty floor grille has been specifically designed for cill and floor applications where light foot traffic will be experienced.

In addition, the AFG is available with any of the airline cores which then makes the product ideal for sidewall applications where reinforced recessed frames are necessary.

The AFG is constructed from aluminium alloy extrusions with tube type cores and fully welded frames. The core is supported by rear reinforcing bars.

### Product Description

**AFG** Light duty floor grille

**OBSS** Allen key operated opposed blade damper

**ED** Equalising deflector

**PB** Plenum box

### Features

- Removable cores for easy access and cleaning
- Core retaining clips for security/safety
- Various core styles
- Recessed frame detail
- Robust enough for light foot traffic on floors or cills
- Suitable for low level sidewall applications
- Solid extruded blades

### Finishes

PPM9006 (RAL 9006 Matt Silver)

PPM9010 (RAL 9010 20% Gloss White)

PPG9010 (RAL 9010 Gloss White)

Nylon Decanol

Other colours available on request

### Weights

12.0kg/m<sup>2</sup> face area

### Sizes

Minimum size - 150 x 50

Maximum size - 1500 x 200

Height and Width increments: 50mm

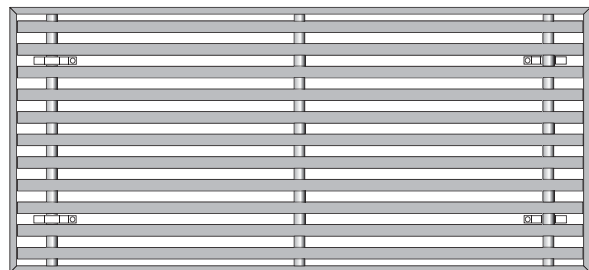
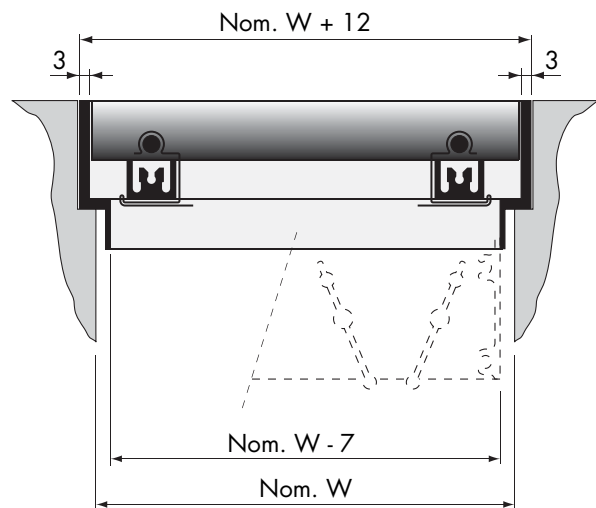
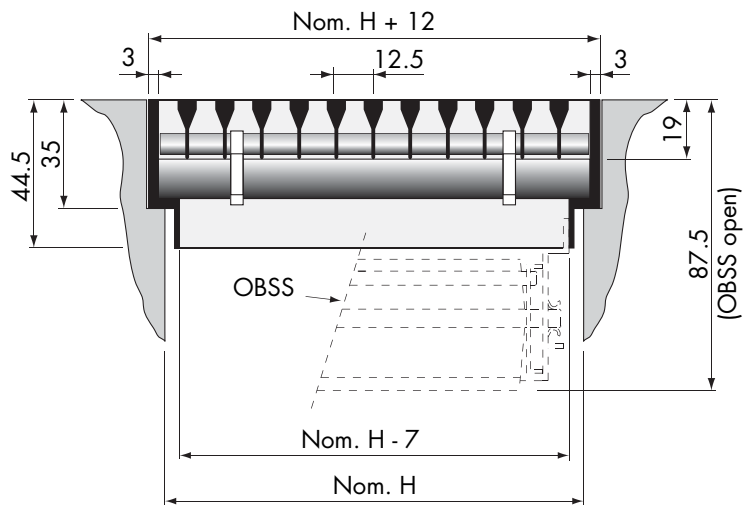

### Order Example

**AFG/1500x150/PPM9010**

Type

Nominal Width

Nominal Height

Finish

**Free Area**

**49%**

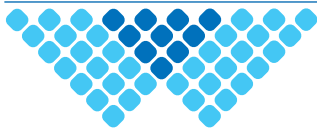

# Light Duty Floor Grilles

## AFG

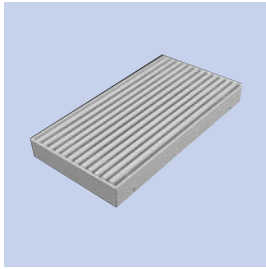

### Selection Criteria

Performance data is based on isothermal conditions for a 1.25m long grille mounted adjacent to a wall surface. NC values are equal to the peak sound power level on NC curves less 8dB allowance for room absorption (SWL re  $10^{-12}W$ ).

Throw is the distance to where the envelope velocity equals 0.5m/s. For grilles mounted more than 500mm from a wall reduce the throw by  $\frac{1}{3}$ .

### Selection Example AFG/2000/50

Air Volume 150 l/s/m

Throw = 11.2m

NC level = NC30 +2dB length correction = NC32

$P_s = 42 Pa$

#### Exhaust Air Correction Factors

Static pressure loss = supply pressure x 1.2  
NC level = supply NC + 4dB

#### Terminal Velocity Correction Factors

Vt (m/s)	0.6	0.5	0.4	0.3
Throw multiplier	0.8	1.0	1.3	1.66

#### Grille Length Correction Factors

Length (m)	0.25	0.5	1.25	2	2.5	3
NC addition	-6	-3	0	+2	+3	+5
Throw x	0.9	0.9	1.0	1.0	1.1	1.1

#### Non-isothermal Jet Correction Factors

Differential	10°C cooling	0°C	10°C heating
Sidewall throw	0.9	1.0	1.0
Cill throw	0.9	1.0	1.1

#### Distributed load (typically foot traffic)

Grille height (mm)	100	200
Max. static load (kg)	960	480
Max. shock load (kg)	384	192

Safety factors: Static load = 2, Shock load = 5

#### Point load

(25x25mm point load over any 2 blades)

Grille height (mm)	up to 200
Max. static load (kg)	105
Max. shock load (kg)	42

### Performance Nomogram

